

# 자동차공업에서의 아크 브레이징 - MIG Brazing과 대비한 Plasma Brazing의 장단점

석한길 · Robert-Killing · 정우현 · 방한서

## Arc Brazing in the Automotiv Industry - Plasma Brazing versus MIG-Brazing- Advantages and Disadvantages

Han-Gil Suk, Robert-Killing, Woo-Hyeon Chung and Han-Sur Bang

### 1. Introduction

In the automotive industry, the increasing number of zinc-coated plates has been manufactured. Since that time the development in joining changes more and more from MAG-Welding to MIG-Brazing. The reason is that the zinc vapour originating from the surface coating in gas-shielded-metal-arc welding penetrates the arc region and causes disturbance to the process. Unquiet arcs and severe spattering are the results. The zinc layer beside the bead will be damaged by the influence of the welding heat. Therefore the necessary corrosion resistance is maintained. Expensive pre-zincing is necessary. That too, is valid for the unalloyed MAG bead itself. Furthermore zinc vapour may cause pore formation in the beads and lead to strong formation of fume.

These disadvantages persist in MIG-Brazing in a much smaller scale, because the apparent temperatures are essentially lower and the originated bead is corrosion resistant by its chemical composition.

The definition of welding and brazing and the differences between both processes are listed in Table 1.

### 2. Principles and special features of the processes

#### 2.1 MIG-Brazing

Fig. 1 shows the principle of MIG-Brazing. The copper base wire coming from the reel is, fed by the wire-feeding device via the feeding hose to the torch. Because of the low strength of the brazing wires compared with steel wires, the length of the feeding hose package should be not more than 3 m. The push/pull-drives are the most favourable. Also because of the low strength of the wires, multi-roller-drives and rollers with rounded grooves are recommended. For shielding purpose inert gases as well as inert gases with small amounts of active components are applied.

The rectifiers or inverters used have constant voltage characteristic and should be exactly adjustable in the lower performance range. Uniform current as well as pulsed current can be used.

Compared with MIG-Welding, MIG-Brazing requires a somewhat different welding technique. To minimize the dilution with the parent material, the torch has to be manipulated in a slight forehand technique and the arc should be directed to a small portion of fore running pool. This hinders excessive penetration into the parent material.

**Table 1** Differences between welding and brazing

Definition of Welding acc. to DIN 1910	Definition of Brazing acc. to DIN 8505
<p>Welding is joining of materials in the welding zone by using of heat and/or power, with or without filler metals. It can be assisted or enabled by auxiliary agents as for example shielding gas, fluxes or pastes. The energy necessary for welding will be transferred external.</p> <p>Fusion welding is joining by local limited melting with or without filler metal.</p>	<p>Brazing is a process for joining metallic materials by use of molten filler metals occasionally under use of brazing fluxes.</p> <p>The melting temperature of the filler is lower than that of the parent material to be joint</p> <p>The workpieces in the joining zone are only wetted without melting.</p>
<p><b>Definition of Welding acc. to ISO 857 1</b></p> <p>Metal welding: Operation which unifies by means of heat or pressure, or both, in such a way, that there is continuity in the nature of the metal what has been joined.</p> <p><b>Fusion welding:</b> Welding without application of outer force in which the faying surface has to be molten; usually, but not necessarily, molten filler metal is added.</p>	<p><b>Definition of Brazing acc. to ISO 857-2</b></p> <p>Soldering/Brazing: Joining processes in which, during or after heating, molten filler metal is drawn into or retained in the space between closely adjusted surfaces of the parts to be joined by capillary attraction.</p> <p><b>Brazing:</b> Joining process using filler material with a liquidus temperature above 450 °C.</p>

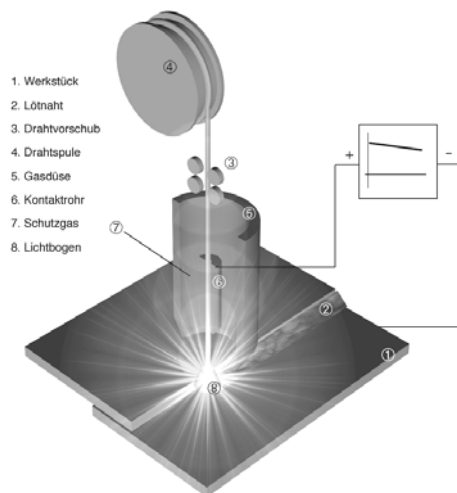
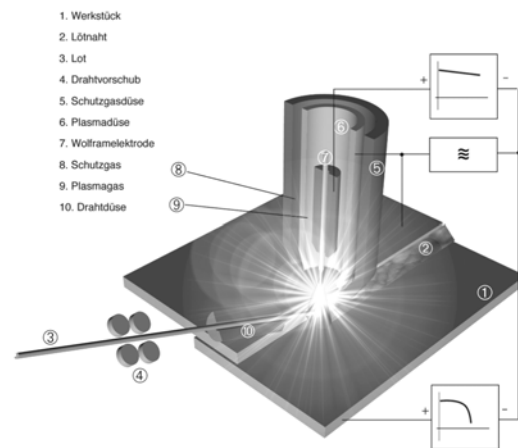
**Fig. 1** Principles of MIG-Brazing**Fig. 2** Principles of Plasma-Brazing

## 2.2 Plasma-Brazing

The principle of Plasma-Brazing can be seen in Fig. 2. Here too, uniform direct or pulsed current can be used. The welding power sources have dropping characteristic.

The constriction of the arc by a water-cooled copper nozzle increases the energy density of the arc. Two shielding gas flows are necessary. For the inner gas stream of the plasma gas, only inert gases are applied. The outer shielding gas can also contain small amounts of active components.

Because of the torch design, the contact ignition between tungsten electrode and work piece is impossible. Therefore the welding facility is equipped with a high-voltage impulse ignition device for touch-less ignition.

The brazing wire can be fed manually or automatically. The plasma head is positioned at a little bit trailing edge and the wire is fed behind the torch and very close beneath the arc (Fig. 3). This way the arc is not burning on the parent material but directed more to the molten pool. Therefore the dilution is very small.

**Table 2** The most important brazing alloys

Grade	DIN Designation	Alloying Basis	Melting Range °C
Silicon Bronze	SG CuSi3	Cu + 3% Silicon	910-1025
Tin Bronze	SG CuSn6	Cu + 6% Tin	910-1040
Aluminium Bronze	SG CuAl8	Cu + 8% Aluminium	1030-1040

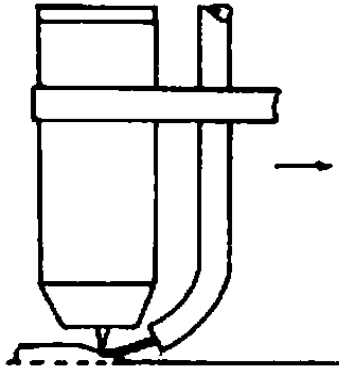

**Fig. 3** Cold wire position to the torch in Plasma-Brazing

**2.3 Filler Materials for Arc Brazing**

For arc brazing copper base alloys are applied. The most important alloys are shown in Table 2. Furthermore there are some special alloys with increased tin or aluminium content. The melting range of all these alloys is not essentially over 1000°C. The filler most used for zinc-coated sheets is the silicon bronze SG-CuSi3. For aluminised sheets the aluminium bronze SG-CuAl8 is better. The later is also applied for high tensile steels.

The filler materials can be delivered with diameters between 0.8 and 1.2 mm. The diameter

used most is 1.0 mm.

Because of the low melting range of the filler alloys, the temperature of the brazing pool is much lower than that of the welding pool. Therefore lower heat input can be achieved. The parent material should not be melted, because joining mechanisms in brazing are diffusion and mechanical adhesion.

**2.4 Advantages of Plasma-Brazing**

Although MIG-Brazing has already been introduced in the car industry in a great scale, nowadays Plasma-Brazing finds increasing use.

The advantages of Plasma-Brazing therefore, in the last time have been the subject of technical conferences and publications in Germany<sup>1,2)</sup>. Some criteria speak for Plasma-Brazing instead of MIG-Brazing. They are listed in Table 3 and will be discussed in more detail as follows.

**a) Advantages related to joining**

- Better bead appearance
- Higher strength and toughness of the brazing metal
- Lower heat input
- Protection of metallic coating on the surface

**Table 3** Suitability of different brazing processes in mechanized brazing of thin sheets

Property/Process	MIG-Brazing	Plasma-Brazing
Bridgeability for gaps	excellent	good
Process velocity	high	high
Sensitiveness for pores	normal	small
Spatter formation	normal	small
Beat appearance	normal	excellent
Toughness of the beat	normal	excellent
Heat input	normal	small
Damage of the zinc layer	normal	small
Use in position	good	good

### b) Advantages related to efficiency

- Lower amount of investigation compared with laser brazing
- Smaller and thinner brazing bead
- Lower consumption of filler metals
- Less re-working, if this is necessary, for instance in visible areas

Some of the advantages of Plasma-Brazing are connected with the matter, that in this process the arc current and the wire-feeding rate are disconnected. For instance if in the MIG-Brazing with higher speed the arc needs more energy, the deposition rate is also increased automatically. However in Plasma-Brazing also with high brazing speed the use of low filler-feeding rate is possible. This leads to thinner and smaller beads that ask for less re-working in visible areas. But also the constriction of the arc itself causes smaller beads. Another advantage of the disconnection of current and wire feed is, that the current can be adjusted as low as even very low heat input is possible. This way the zinc coating is protected from the evaporation and burn-off on the surface and at the rear site of the sheets. Furthermore the distortion of the sheets after brazing is lower.

The strength and the toughness of the brazing metal are influenced especially by the amount of iron that trends into the bead by dilution with parent metal by the arc. Iron is soluble in copper only to a small extent. So it is precipitated as trample inclusions in the form of globules or dendrites. With increasing amount of these inclusions the strength and the toughness of the bead is decreasing. Because of the disconnection of current and wire feed, Plasma-Brazing allows the dosing of brazing wire so exactly that the arc burns on a small tongue of fore-running pool and does not penetrate the parent material. Figs. 4 and 5 show the joining areas in MIG-Brazing and Plasma-Brazing. The filler is the silicon bronze SG-CuSi3. As already mentioned before, the joining mechanisms in brazing are the diffusion and mechanical adhesion. For the diffusion the heat transferred via the pool is sufficiently high enough. Therefore

compared with the MIG- Brazing (see Fig. 4), the joining border in the Plasma- Brazing is more straight-lined (Fig. 5).

### 3. Equipments for Plasma-Brazing

Fig 6 shows the modern equipment for Plasma-Brazing. The components are the inverter power source, the cooling device, the trolley for

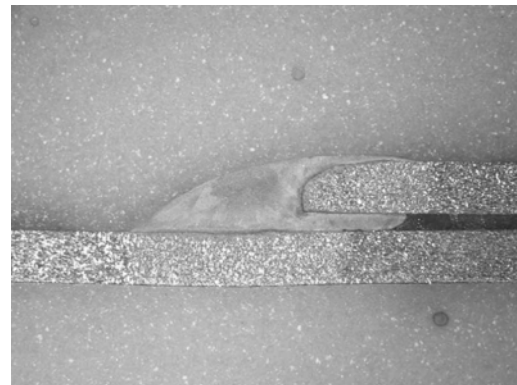

Fig. 4 Macro section from a MIG-Brazing joint

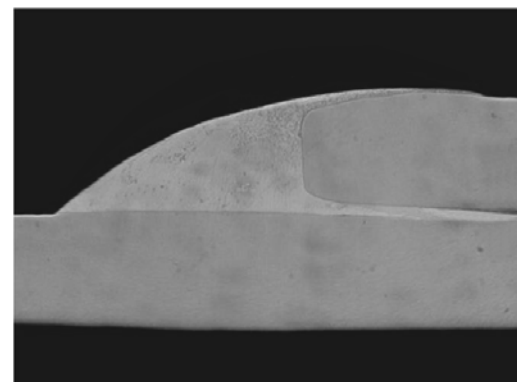

Fig. 5 Macro section from a Plasma-Brazing joint

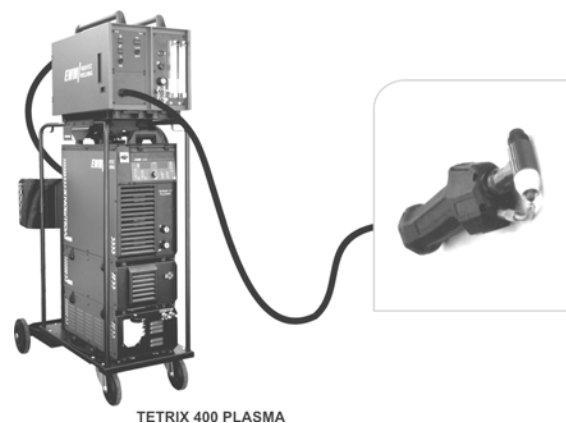

Fig. 6 Equipment for Plasma-Brazing

transportation, the filler metal drive with a feeding hose and the torch. In this case the plasma torch for manual application with an integrated cold wire feed is used, but in the manual brazing of short beads the filler can also be added by hand in the form of rods.

For fully automatic application, additional facilities for guiding the torch along the work piece as longitudinal driveways or industrial robots are necessary.

#### 4. Application in Practice

Several European motor companies have introduced Plasma-Brazing already into fabrication.

Long beads are brazed automatically, short ones manually. In Fig. 7 manual Plasma-Brazing is done on an outside door panel of a body for a private motorcar. Other examples for application for instance are joints on doorframes and mudguards. The typical parameters for robot brazing on long and thin joints at 0.8 mm thick sheets on car bodies are according to <sup>2)</sup>:

- Current: 75 Ampere
- Brazing speed: 42 cm/min
- Cold wire addition: 6.1 m/min
- Filler material: SG-CuSi<sub>3</sub>
- Shielding gas: Argon



Fig. 7 Plasma-Brazing in the Automotive Industry

#### Literature:

- 1) Bouafi, B., B. Quaiassa, J. Tuchfeld, A. Ait-Mekideche and C. Radscheid:  
Plasmalöten von verzinkten Blechen - Stand und Entwicklungstendenzen im Karosseriebau DVS-Berichte Band 204, S. 183-190 - Public house of the German Welding Society  
DVS-Verlag GmbH, Düsseldorf, 1999
- 2) Susa, F.:  
Wirtschaftliche und verfahrenstechnische Vorteile des Plamalötens  
DVS-Berichte Band 232, S. 259-263 - Public house of the German Welding Society  
DVS-Verlag GmbH Düsseldorf, 2004



- 석한길
- 1954년생
- 삼척대학교 재료금속과
- 용사, 용접야금, 가공
- e-mail: hgsuk@mail.kangwon.ac.kr



- 정우현
- 1956년생
- KISEL 기술연구소
- 철강재료, 용접재료개발
- e-mail: sendung@hanmail.net



- 방한서
- 1951년생
- 조선대학교 선박해양공학과
- 용접 역학 및 공정
- e-mail: hsbang@mail.chosun.ac.kr